

# SPECIFICATION



## Contents

- 1. Description
  - 1.1 General Description
  - 1.2 Features
  - 1.3 Application
  - 1.4 Package Dimension
  - 1.5 Product Parameters
  - 1.6 Typical Optical Characteristics Curves
- 2. Packaging
  - 2.1 Packaging Specification
    - 2.1.1 Carrier Tape Dimension
    - 2.1.2 Reel Dimension
    - 2.1.3 Label Form Specification
  - 2.2 Moisture Resistant Packing
  - 2.3 Cardboard Box
  - 2.4 Reliability Test Items And Conditions
  - 2.5 Criteria For Judging Damage
- 3. SMT Reflow Soldering Instructions SMT
  - 3.1 SMT Reflow Soldering Instructions SMT
- 4. Handling Precautions
  - 4.1 Handling Precautions



scrip

## 1.1 General Description

This product uses BT package, has a high reliability.

Size(mm): 4.42mmX2.76mmX3.74mm.

BT

4.42mmX2.76mmX3.74mm.

## 1.2 Features

- ▶ Low forward voltage.
- ▶ Peak wavelength  $\lambda_p=940\text{nm}$ .  $\lambda_p=940\text{nm}$
- ▶ Suitable for all SMT assembly and solder process.
- ▶ Moisture sensitivity level: Level 3.
- ▶ RVs



## 1.4 Package Dimension

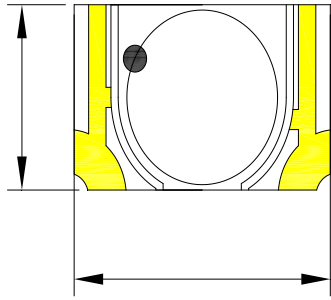

Fig.1-1 Top view

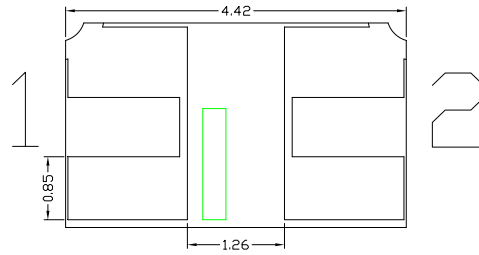

Fig.1-2 Bottom view

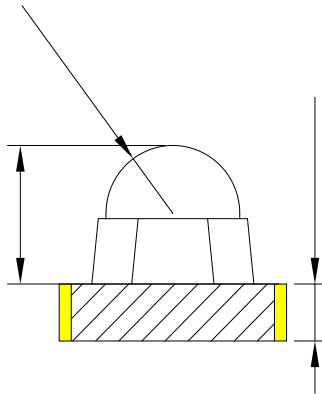

Fig.1-3 Side view

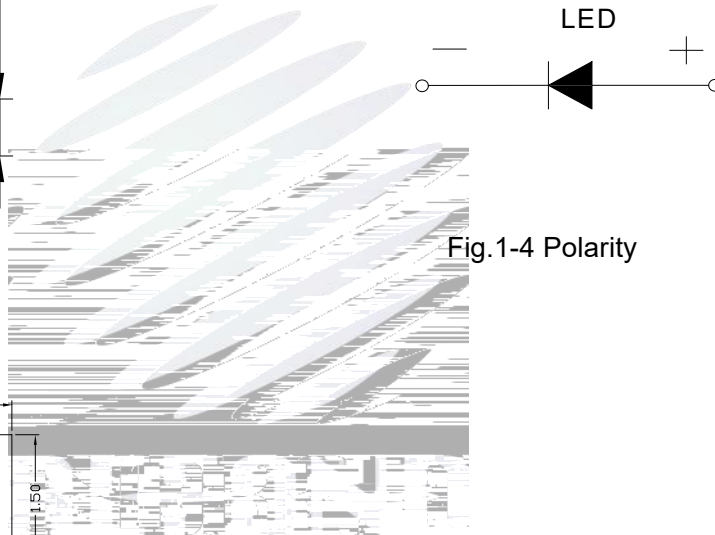

Fig.1-4 Polarity

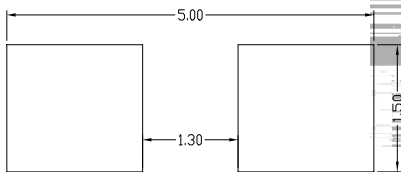

Fig.1-5 Soldering patterns

### Notes

All dimensions units are millimeters.

All dimensions tolerances are  $\pm 0.2\text{mm}$  unless otherwise noted.

## 1.5 Product Parameters

Table 1-1 Electrical / Optical Characteristics at Ts=25°C

Item	Symbol	Test Condition	Value			Unit
			Min.	Typ	Max.	
Reverse Current	$I_R$	$V_R=5V$	---	---	5	$\mu A$
Forward Voltage	$V_F$	$I_F=50mA$	1.1	1.3	1.6	V
Peak Wavelength	$\lambda_p$	$I_F=50mA$	---	940	---	nm
Spectrum Radiation Bandwidth	$\Delta\lambda$	$I_F=50mA$	---	45	---	nm
Radiant Intensity	$\Phi_e$	$I_F=50mA$	60	---	---	mW/sr
Viewing Angle	2 $\theta$ 1/2	$I_F=50mA$	---	30	---	deg
Thermal Resistance.	$R_{THJ-S}$	$I_F=50mA$	---	450	---	/W

Notes :  $V_R=5V$  For test conditions:  $V_R=5V$



Notes

1. 1/10 Duty cycle, 0.1ms pulse width.
  2. The above forward voltage measurement allowance tolerance is  $\pm 0.1V$ .
  3. The above dominant wavelength measurement allowance tolerance is  $\pm 2nm$ .
  4. The above luminous intensity measurement allowance tolerance  $\pm 10\%$ .
  5. Care is to be taken that power dissipation does not exceed the absolute maximum rating of the product.
  6. All measurements were made under the standardized environment of Refond.
- When the LEDs are in operation the maximum current should be decided after measuring the package temperature, junction temperature should not exceed the maximum rate

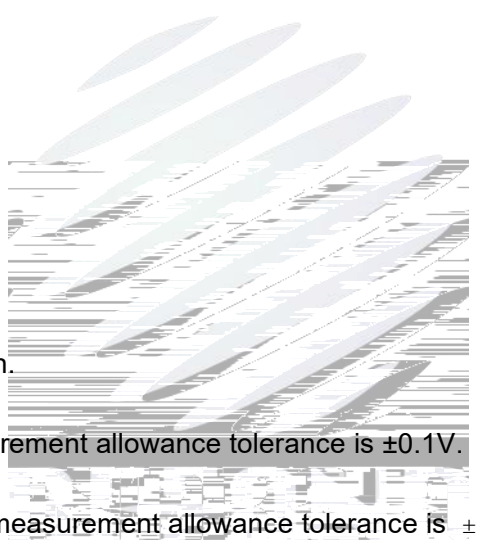

## 1.6 Typical Optical Characteristics Curves



Fig 1-6 Forward Voltage Vs Forward Current

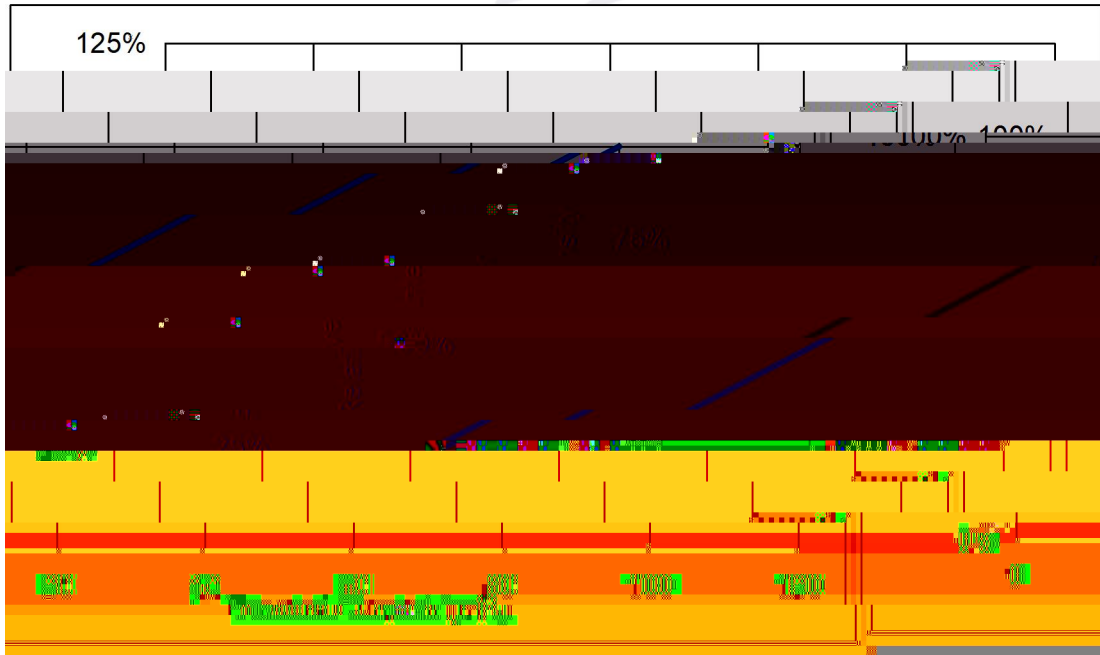

Fig 1-7 Forward Current Vs Relative Intensity

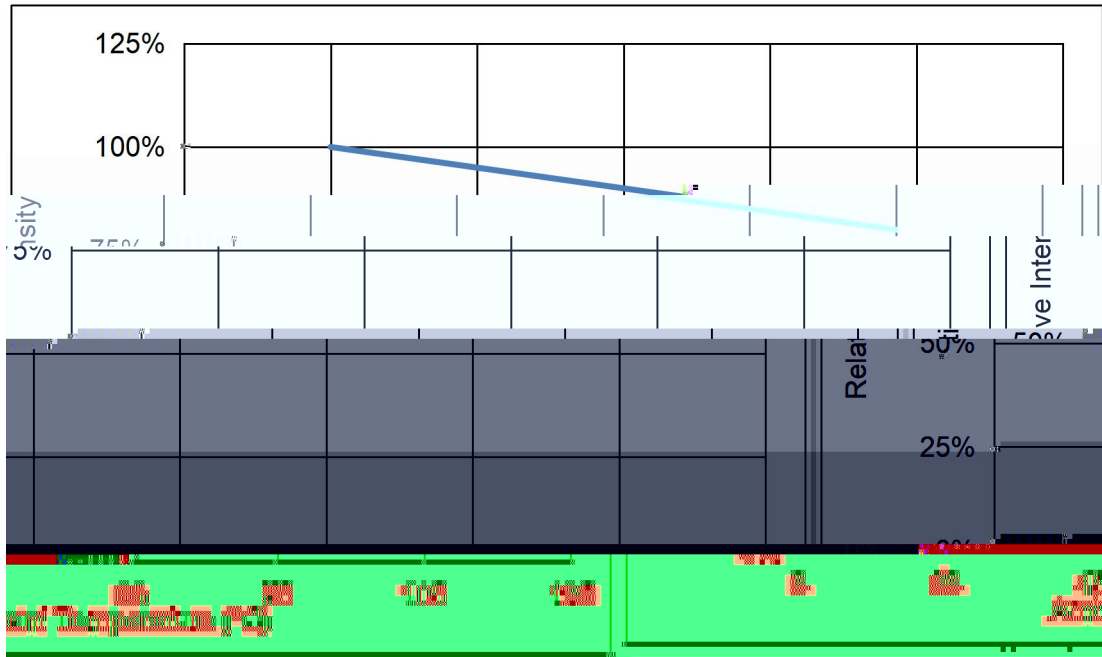

Fig 1-8 Pin Temperature Vs Relative Intensity

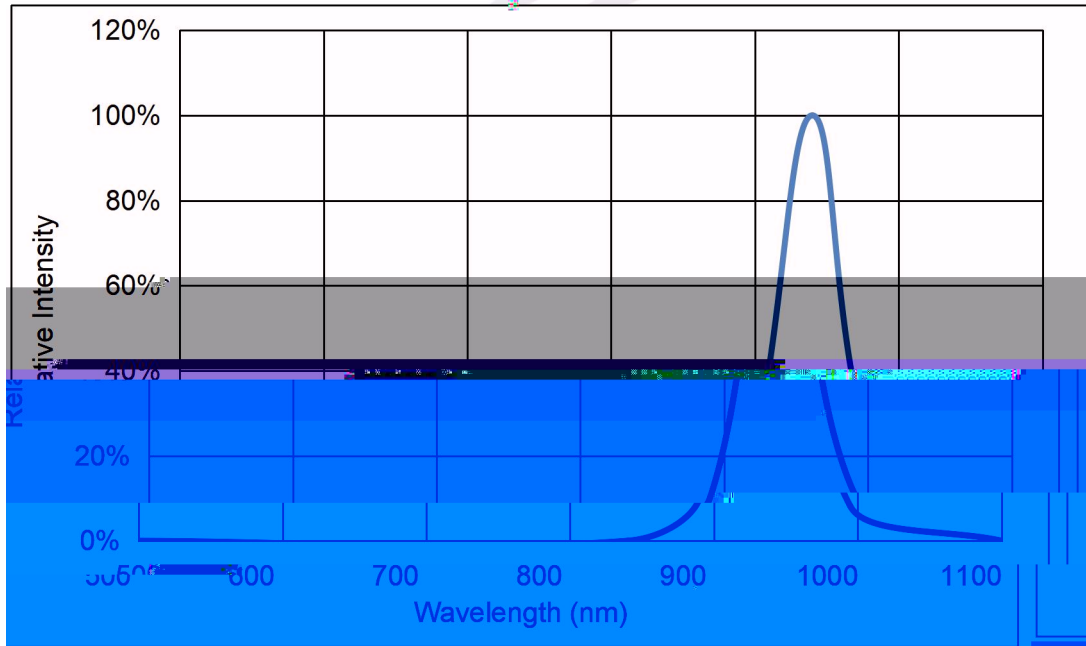
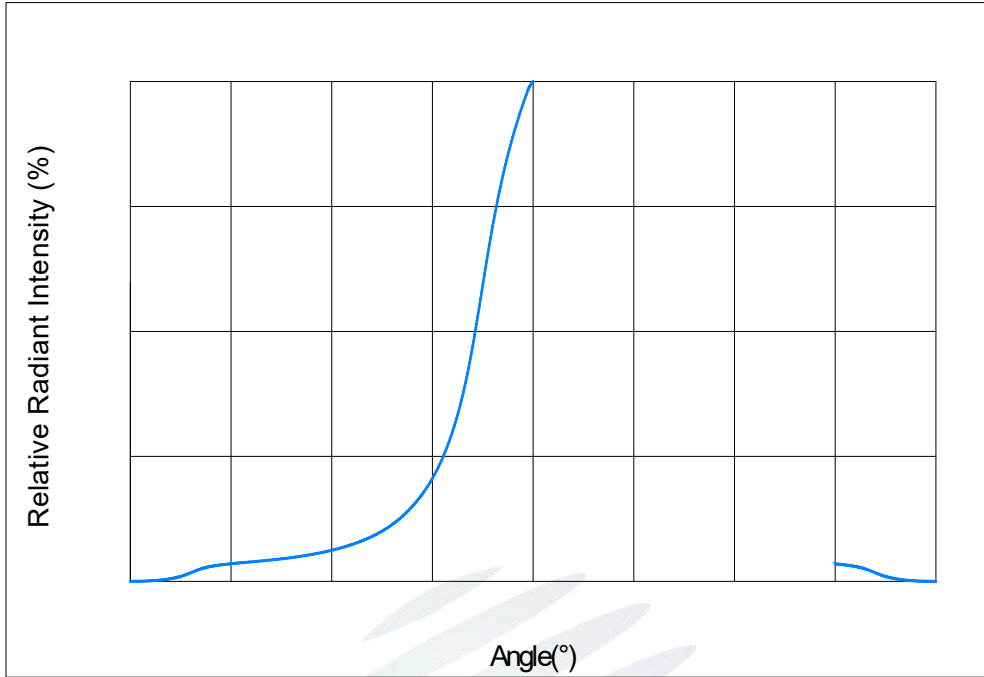

Fig 1-9 Spectrum Distribution





## 2. Packaging

### 2.1 Packaging Specification

Package: 2500pcs/reel.      2500pcs

#### 2.1.1 Carrier Tape Dimension

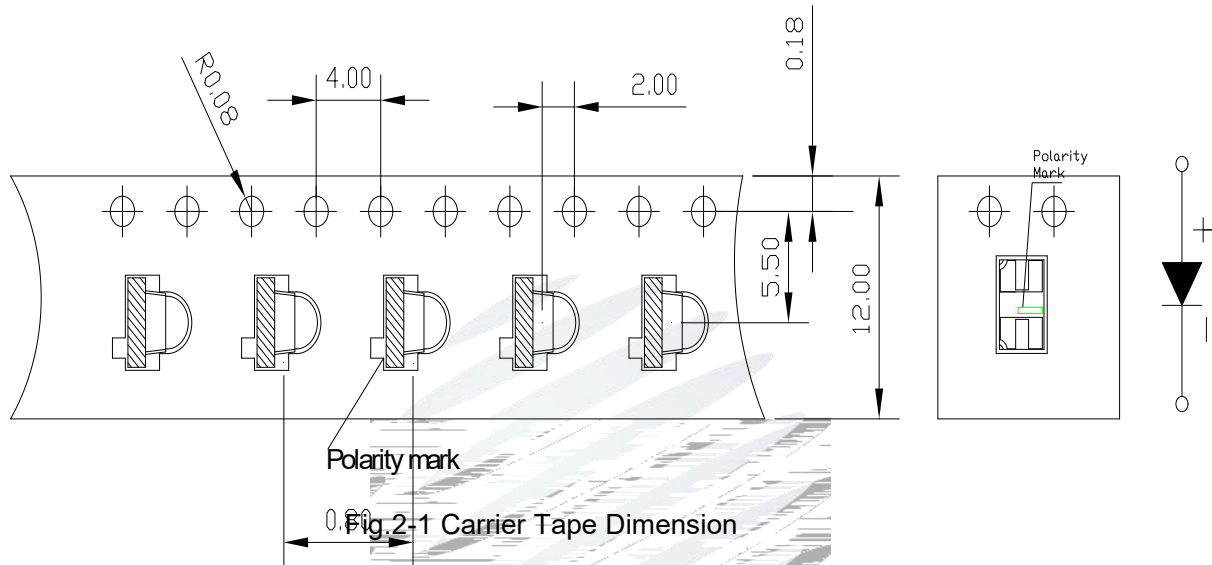

#### 2.1.2 Reel Dimension

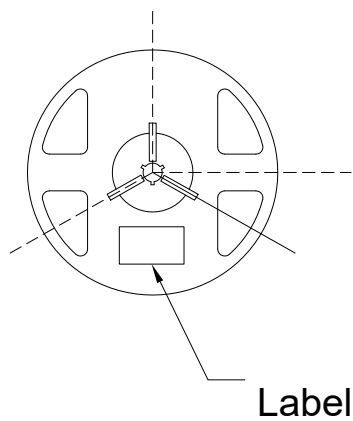

Fig.2-2 Reel Dimension

Table 2-1 Dimension

A	12.7 ±0.3mm
B	330.2±2mm
C	79.5±1mm
D	14.3±0.2mm

#### Notes

The tolerances unless mentioned  $\pm 0.1\text{mm}$ . Unit : mm

### 2.1.3 Label Form Specification S



## 2.4 Reliability Test Items And Conditions

Table 2-3 Reliability Test Items And Conditions

Test Items	Ref.Standard	Test Condition	Time	Quantity	Ac/Re /
Reflow	JESD22-B106	Temp:260 max T=10 sec	2 times	22Pcs.	0/1
Temperature Cycle	JESD22-A104	100 30 min ↑↓5 min -40 30 min	100 cycles	22Pcs.	0/1
Thermal Shock	JESD22-A106	-40 15min ↑↓ 100 15min	300 cycles	22Pcs.	0/1
High Temperature Storage	JESD22-A103	Temp:100	1000 hrs.	22Pcs.	0/1
Low Temperature Storage	JESD22-A119	Temp:-40	1000 hrs.	22Pcs.	0/1
Life Test	JESD22-A108	T <sub>a</sub> =25 I <sub>F</sub> =100mA	1000 hrs.	22Pcs.	0/1



### 3.1 SMT Reflow Soldering Instructions SMT

Fig.3-1 SMT Reflow Soldering Instructions SMT

Table 3-1 Parameter

Average temperature rise speed	$T_{smax}$	$T_P$	3 °C/ s	Max 3 °C/ s
Preheating: minimum temperature	( $T_{smin}$ )		150 °C	
Preheating: Max temperature	( $T_{smax}$ )		200 °C	
Preheating: Time	$T_{smin}$	$T_{smax}$	60 - 120	60s-120s
Time limited to maintain high temperature: the temperature			( $T_L$ )	217 °C
Time limited to maintain high temperature: The Time			( $t_L$ )	60 Max 6



## 4. Handling Precautions

### 4.1 Handling Precautions

(1) LED operating environment and sulfur element composition cannot be over 100PPM in the LED mating usage material. This is provided for informational purposes only and is not a warranty or endorsement. LED

(2) In order to prevent external material from getting into the inside of LED, which may cause the malfunction of LED, the single content of Bromine element is required to be less than 900PPM, the single content of Chlorine element is required to be less than 900PPM, the total content of Bromine element and Chlorine element in the external materials of the application products is required to be less than 1500PPM. This is provided for informational purposes only and is not a warranty or endorsement.

(3) VOCs (Volatile organic compounds) emitted from materials used in the construction of fixtures can penetrate silicone encapsulants of LEDs and discolor when exposed to heat and photonic energy. The result can be a significant loss of light output from the fixture. Knowledge of the properties of the materials selected to be used in the construction of fixtures can help prevent these issues. Refond advises against the use of any chemicals or materials that have been found or are suspected to have an adverse effect on device performance or reliability. To verify compatibility, Refond recommends that all chemicals and materials be tested in the specific application and environment for which they are intended to be used. Attaching LEDs, do not use adhesives that outgas organic vapor.

(4) In designing a circuit, the current through each LED can not exceed the absolute maximum rating specified for each LED. In the meanwhile, resistors for protection should be applied,





(8) Similar to most Solid state devices; LEDs are sensitive to Electro-Static Discharge (ESD) and Electrical Over Stress (EOS).

(9) Other points for attention, please refer to our relevant information.







Declare

This specification is written both in English and in Chinese and the latter is formal.