

Contents

1. Description	
1.1 General Description	
1.2 Features	
1.3 Application	
1.4 Package Dimension	
1.5 Product Parameters	
1.6 The C.I.E Chromaticity Diagram CIE	
1.7 Typical optical characteristics curves	
2. Packaging	
2.1 Packaging Specification	
2.1.1 Carrier Tape Dimension	13
2.1.2 Reel Dimension	13
2.1.3 Label Form Specification	14
2.2 Moisture Resistant Packing	
2.3 Cardboard Box	
2.4 Reliability Test Items And Conditions	
2.5 Criteria For Judging Damage	
3. SMT Reflow Soldering Instructions SMT	
3.1 SMT Reflow Soldering Instructions SMT	
4. Handling Precautions	
4.1 Handling Precautions	

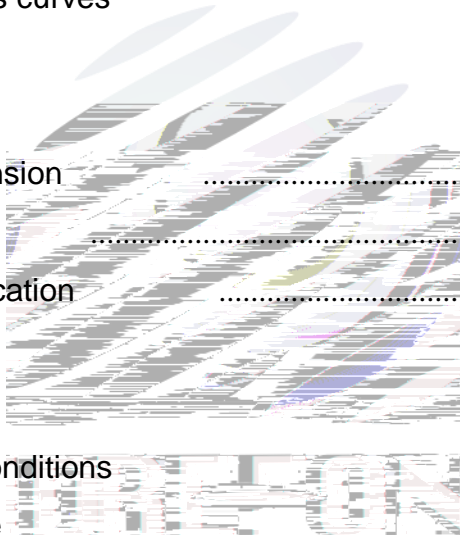

1. Description

1.1

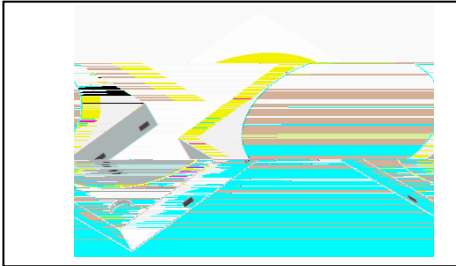

The White LED which was fabricated using a blue chip and the phosphor

3.0mmX3.0mmX0.55mm

1.2 Features

EMC Package. EMC.

Extremely wide viewing angle.

Suitable for all SMT assembly and solder process.

Package: 5000 pcs/reel.

Moisture sensitivity level: Level 3.

RoHS compliant.

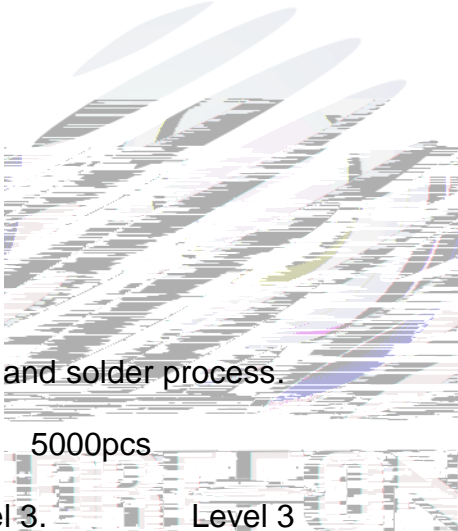

SMT

5000 pcs

Level 3

RoHS

1.3 Application

Optical indicator.

Indoor display.

Outdoor lighting

General use.

1.4 Package Dimension

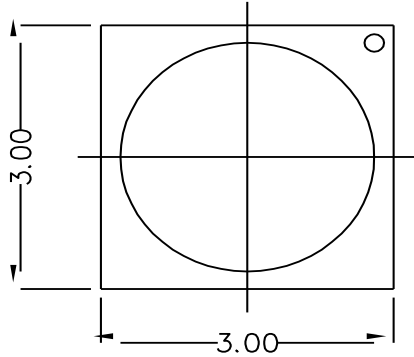

Fig.1-1 Top view

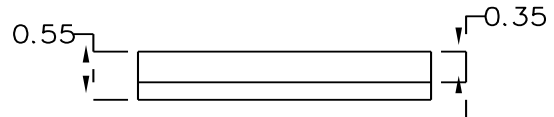
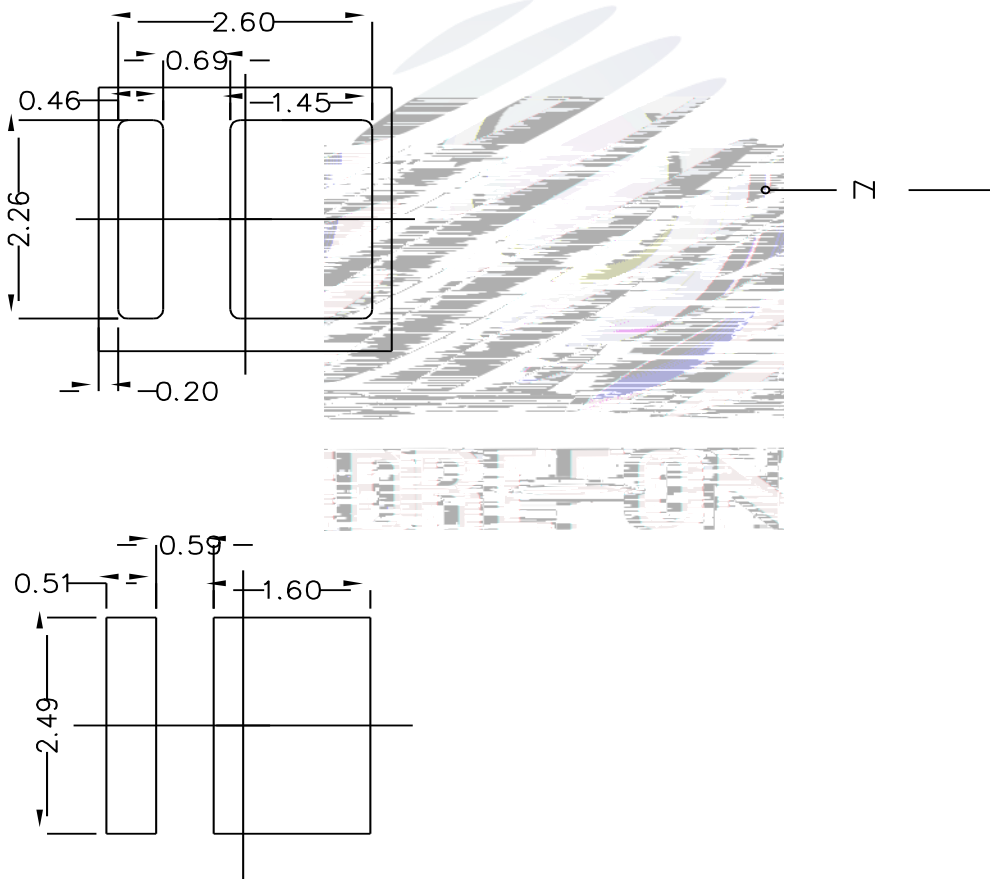

Fig.1-2 Side view



Notes

All dimensions units are millimeters.

All dimensions tolerances are $\pm 0.2\text{mm}$ unless otherwise noted.

±

1.5 Product Parameters

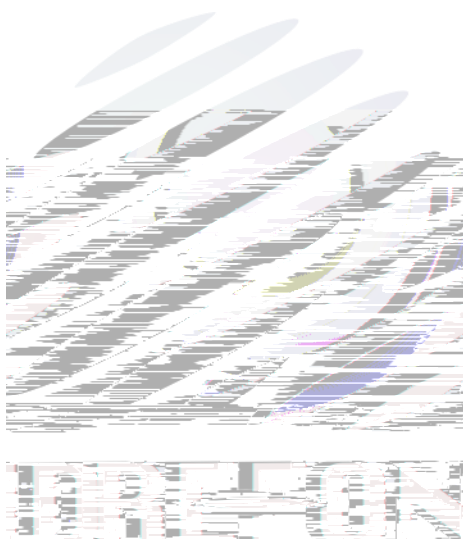

Table 1-2 Absolute Maximum Ratings at Ts=25°C

Parameter	Symbol	Rating	Units
Power Dissipation	P _D	1200	mW
Forward Current	I _F	180	mA
Peak Forward Current	I _{FP}	240	mA
Reverse Voltage	V _R	10	V
Electrostatic Discharge(HBM)	E _{SD}	2000	V
Operating Temperature	T _{OPR}	-40 ~ +100	
Storage Temperature	T _{OPR}	-40 ~ +100	
Junction Temperature	T _J	125	

Notes

- 1/10 Duty cycle, 0.1ms pulse width.
- The above forward voltage measurement allowance tolerance is $\pm 0.1V$. $\pm 0.1V$.
- The above color coordinates measurement allowance tolerance is ± 0.003 . ± 0.003 .
- The above luminous intensity measurement allowance tolerance $\pm 10\%$. $\pm 10\%$.
- Care is to be taken that power dissipation does not exceed the absolute maximum rating of the product.
- All measurements were made under the standardized environment of Refond.
- When the LEDs are in operation the maximum current should be decided after measuring the package temperature, junction temperature should not exceed the maximum rate

1.6 The C.I.E Chromaticity Diagram CIE

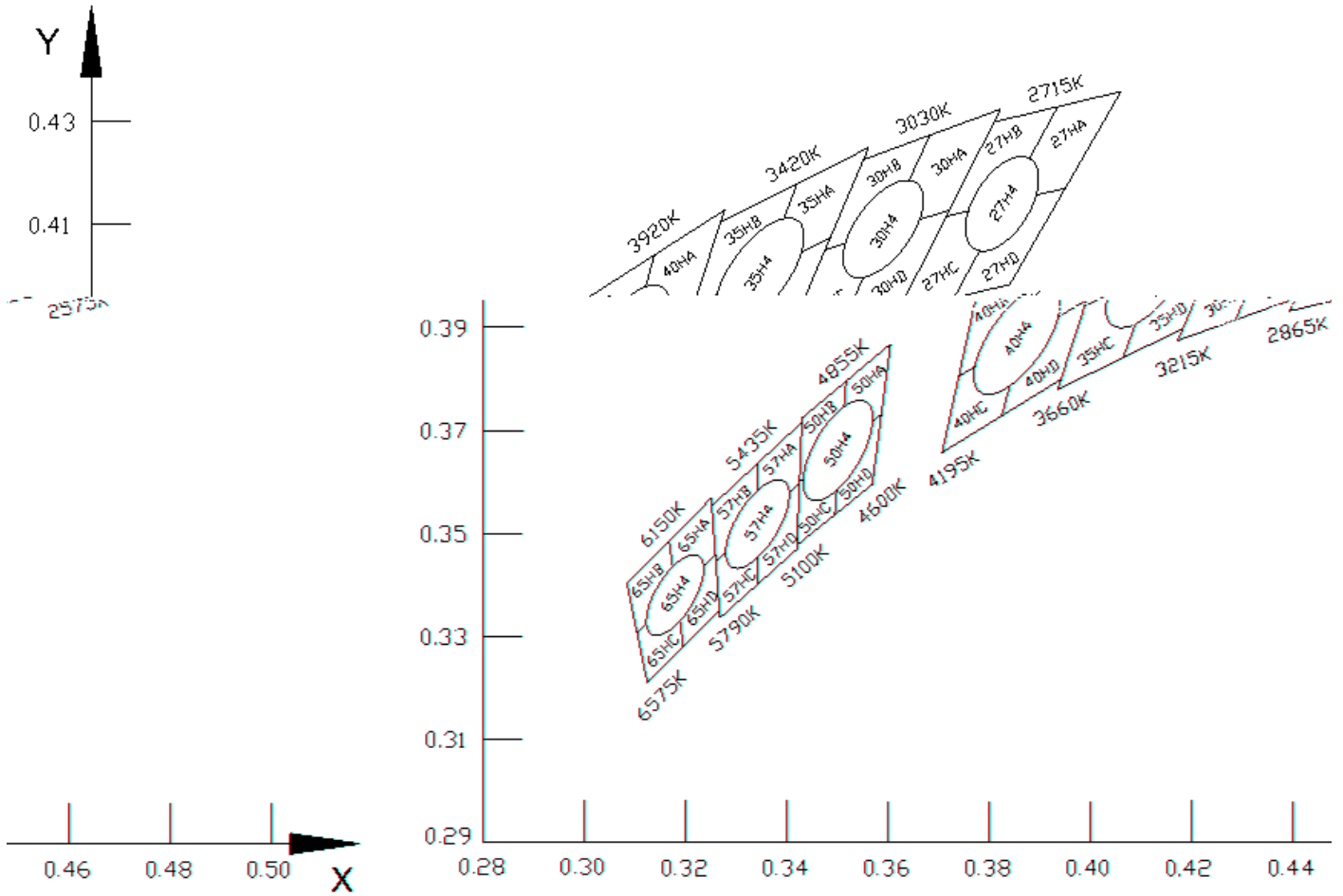

Fig 1-6 The C.I.E Chromaticity Diagram CIE

Bin data

ANSI 4-Step										
Bin Code	X	Y	a	b						
27H4	0.4600	0.4140	0.01032	0.00548	57°17'					
30H4	0.4365	0.4091	0.01112	0.00544	53°10'					
40H4	0.3856	0.3876	0.01252	0.00536	54°00'					
50H4	0.3502	0.3661	0.01096	0.00472	59°37'					
57H4	0.3343	0.3518	0.00980	0.00420	58°00'					
65H4	0.3180	0.3380	0.00892	0.00380	58°23'					
ANSI 7-Step										
Bin Code	X1	Y1	X2	Y2	X3	Y3	X4	Y4	X5	Y5
27HA	0.4835	0.4358	0.4710	0.4329	0.4654	0.4228	0.4668	0.4157	0.4725	0.4171
27HB	0.4710	0.4329	0.4584	0.4299	0.4490	0.4116	0.4533	0.4126	0.4654	0.4228
27HC	0.4395	0.3932	0.4490	0.4116	0.4533	0.4126	0.4555	0.4049	0.4505	0.3958
27HD	0.4505	0.3958	0.4555	0.4049	0.4668	0.4157	0.4725	0.4171	0.4615	0.3983
30HA	0.4597	0.4324	0.4458	0.4274	0.4416	0.4186	0.4437	0.4109	0.4496	0.4128
30HB	0.4458	0.4274	0.4326	0.4226	0.4250	0.4051	0.4290	0.4063	0.4416	0.4186
30HC	0.4174	0.3875	0.4250	0.4051	0.4290	0.4063	0.4326	0.3997	0.4287	0.3915
30HD	0.4287	0.3915	0.4326	0.3997	0.4437	0.4109	0.4496	0.4128	0.4408	0.3957
40HA	0.4051	0.4128	0.3913	0.4040	0.3895	0.3979	0.3937	0.3920	0.3994	0.3953
40HB	0.3774	0.3953	0.3741	0.3805	0.3773	0.3824	0.3895	0.3979	0.3913	0.4040
40HC	0.3708	0.3657	0.3741	0.3805	0.3773	0.3824	0.3842	0.3787	0.3826	0.3728
40HD	0.3943	0.3799	0.3826	0.3728	0.3842	0.3787	0.3937	0.3920	0.3994	0.3953
50HA	0.3606	0.3868	0.3519	0.3796	0.3514	0.3746	0.3571	0.3717	0.3588	0.3732
50HB	0.3431	0.3724	0.3426	0.3601	0.3434	0.3607	0.3514	0.3746	0.3519	0.3796
50HC	0.3421	0.3477	0.3426	0.3601	0.3434	0.3607	0.3500	0.3584	0.3496	0.3536
50HD	0.3570	0.3595	0.3496	0.3536	0.3500	0.3584	0.3571	0.3717	0.3588	0.3732
57HA	0.3431	0.3716	0.3342	0.3635	0.3342	0.3583	0.3406	0.3578	0.3426	0.3596
57HB	0.3253	0.3554	0.3261	0.3445	0.3280	0.3463	0.3342	0.3583	0.3342	0.3635
57HC	0.3269	0.3336	0.3261	0.3445	0.3280	0.3463	0.3344	0.3454	0.3345	0.3406
57HD	0.3421	0.3469	0.3345	0.3402	0.3344	0.3454	0.3406	0.3578	0.3426	0.3596
65HA	0.3252	0.3569	0.3168	0.3485	0.3175	0.3435	0.3237	0.3436	0.3260	0.3459
65HB	0.3085	0.3402	0.3105	0.3307	0.3123	0.3325	0.3175	0.3435	0.3168	0.3485
65HC	0.3125	0.3211	0.3105	0.3307	0.3123	0.3325	0.3190	0.3330	0.3196	0.3280
65HD	0.3268	0.3349	0.3196	0.3280	0.3190	0.3330	0.3237	0.3436	0.3260	0.3459

1.7 Typical optical characteristics curves

Fig 1-9 Forward Voltage Vs. Forward Current



Fig 1-10 Forward Current Vs. Relative Intensity

1.

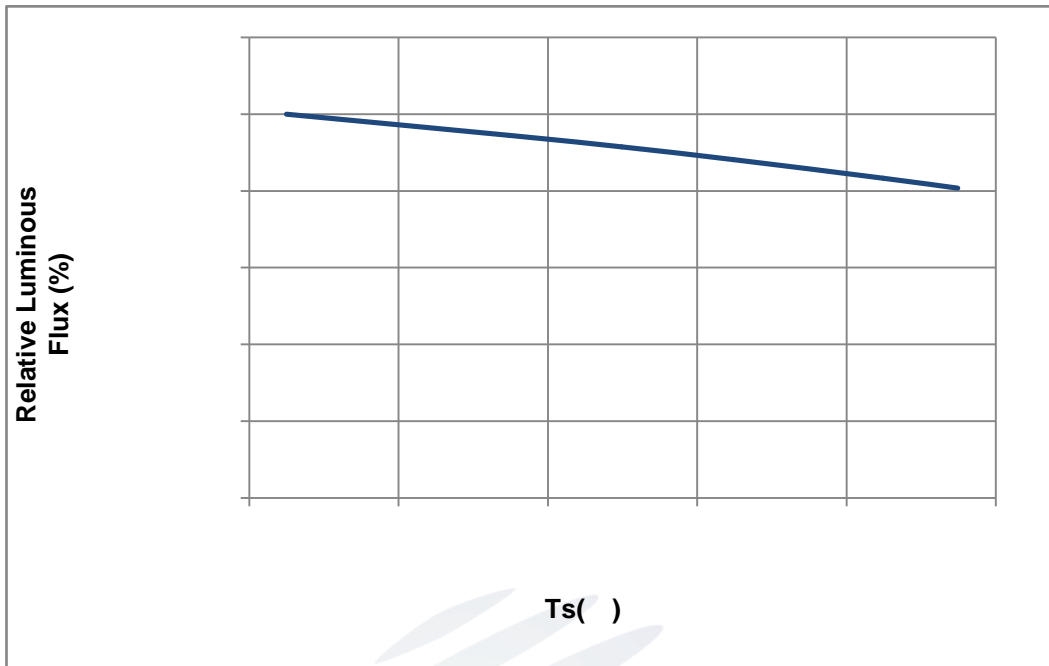

Fig 1-11 Solder Temperature Vs Relative Intensity

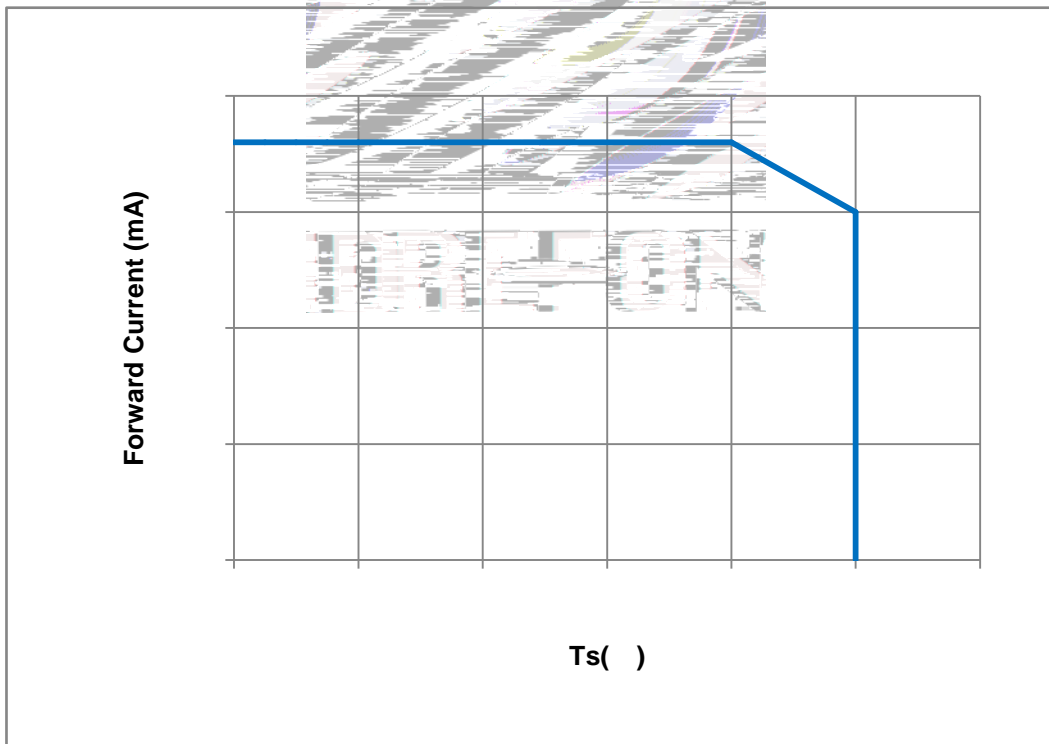

Fig 1-12 Solder Temperature Vs. Forward Current

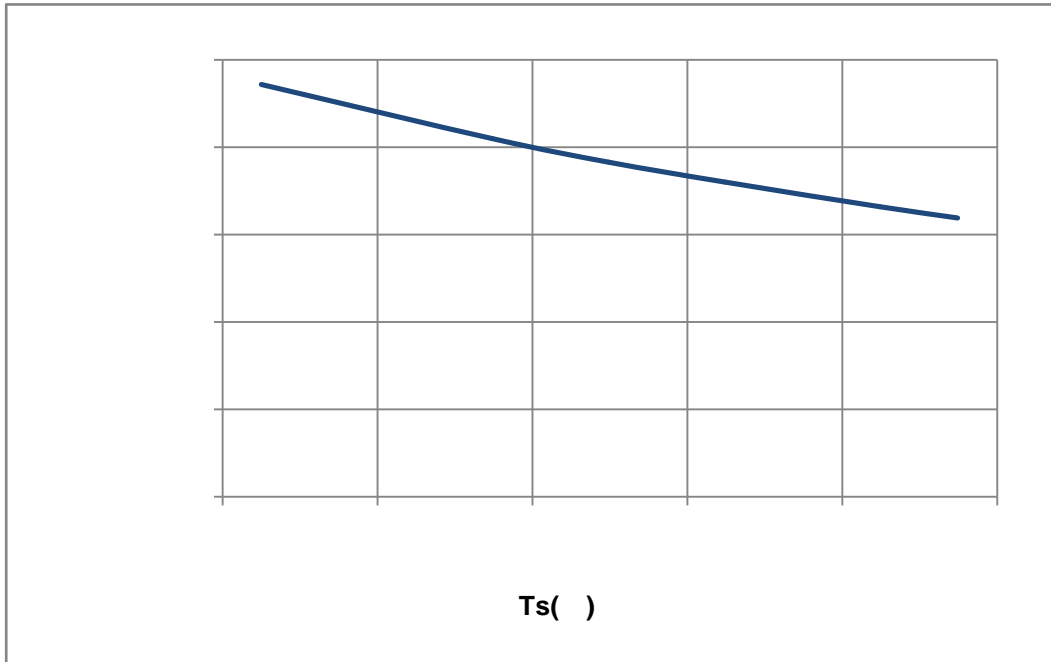

Fig 1-13 Forward Voltage Vs Solder Temperature

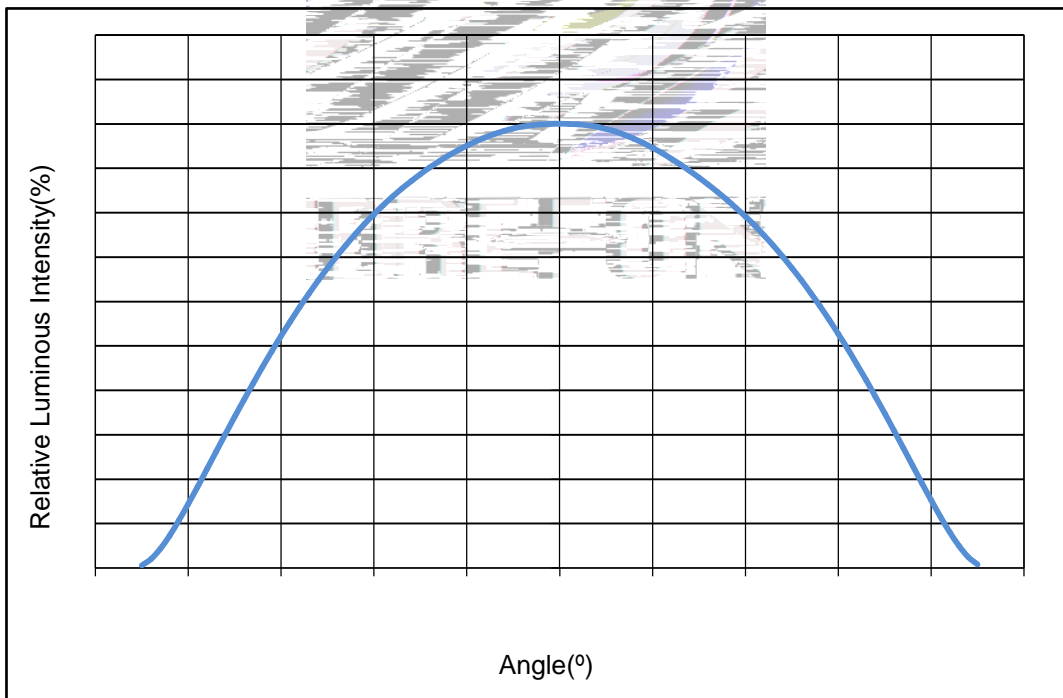
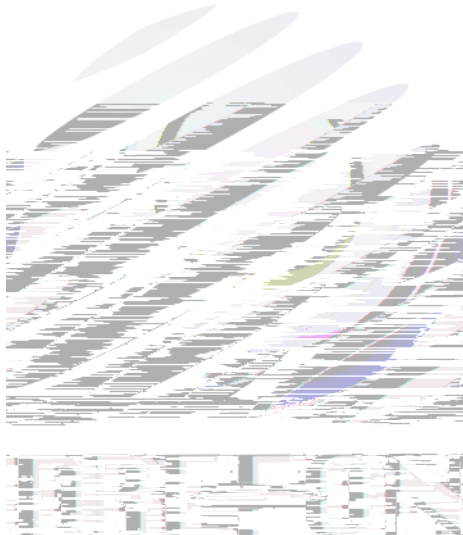

Fig 1-14 Radiation diagram



2. Packaging

2.1 Packaging Specification

Package:5000pcs/reel.

2.1.1 Carrier Tape Dimension

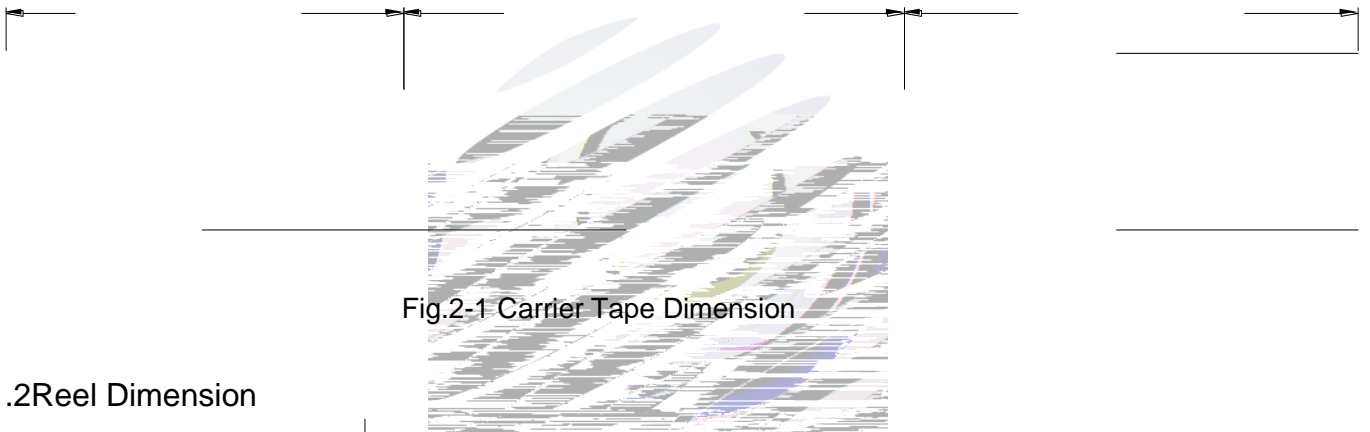
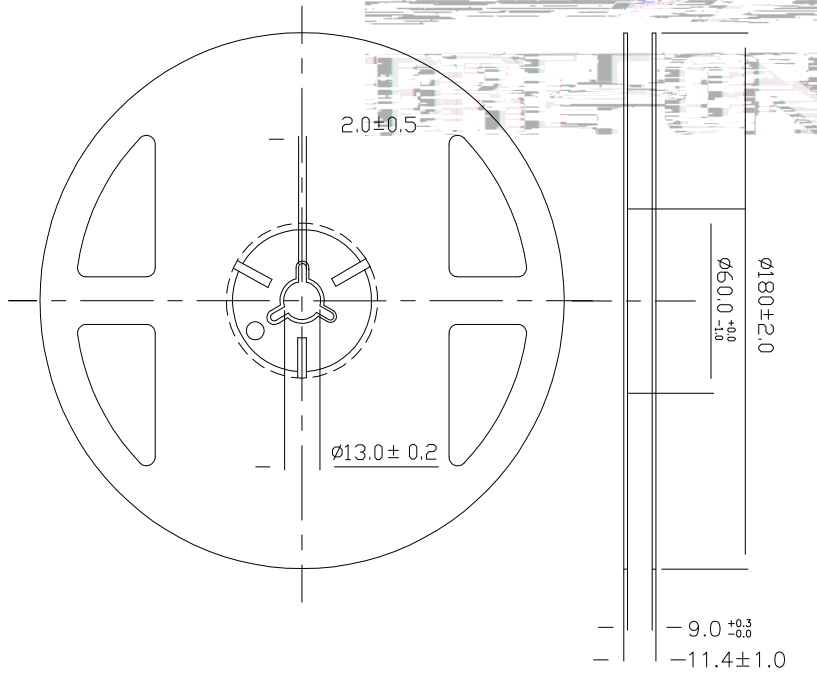

Fig.2-1 Carrier Tape Dimension

2.1.2 Reel Dimension



Notes

The tolerances unless mentioned ± 0.1 mm. Unit : mm $\pm 0.$

2.1.3 Label Form Specification

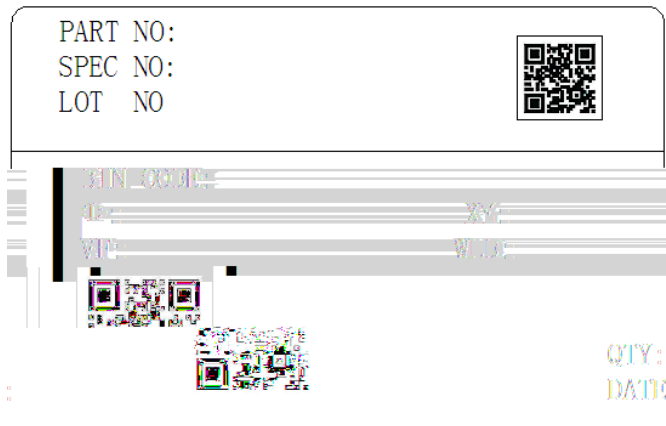

Fig 2-3 Title

PART NO.	Part Number
SPEC NO.	Spec Number
LOT NO.	Lot Number
BIN CODE	Bin Code
	Luminous flux
XY	Chromaticity Bin
V _F	Forward Voltage
WLD	Wavelength
QTY	Packing Quantity
DATE	Made Date

2.2 Moisture Resistant Packing

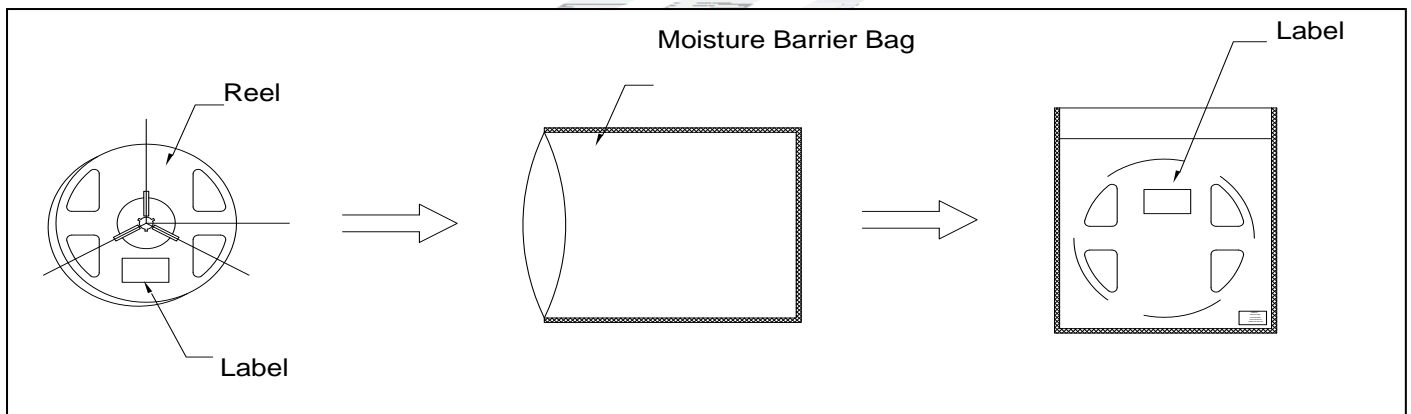

Fig.2-4Title

2.3 Cardboard Box

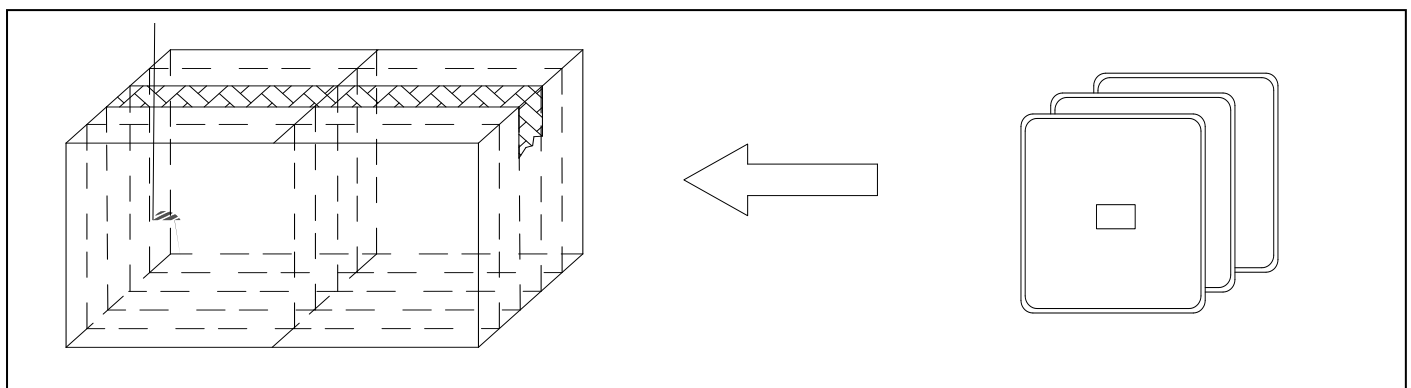
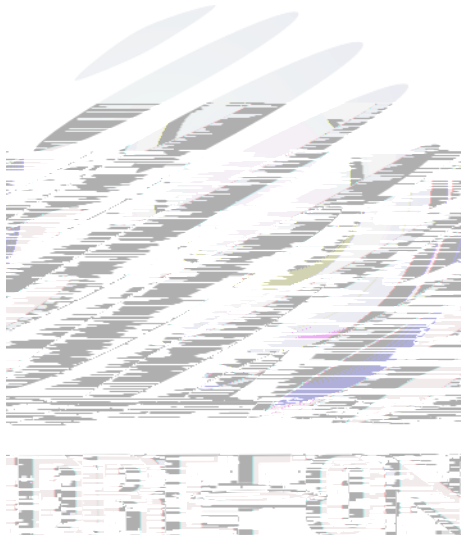

Fig.2-5Title

2.4 Reliability Test Items And Conditions

Table 2-3 Title

Test Items	Ref.Standard	Test Condition	Time	Quantity	Ac/Re
Reflow	JESD22-B106	Temp:260 maxm2			



Notes

- 1.The Reliability tests are based on Refond existing test platform.
2. The technical information shown in the data sheets are limited to the typical characteristics and circuit examples of the referenced products. It does not constitute the warranting of industrial property nor the granting of any license. voltage distribution, heat dissipation and others.

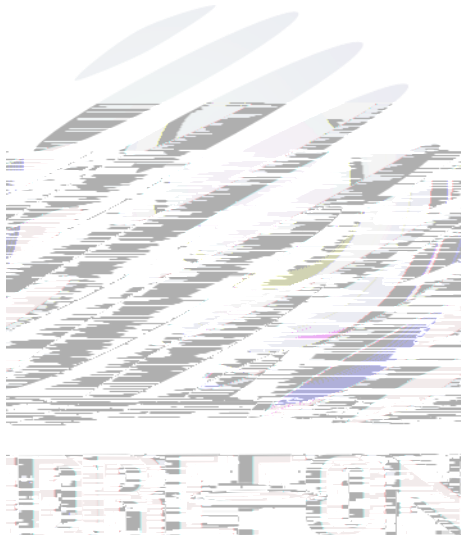

3. SMT Reflow Soldering Instructions SMT

3.1 SMT Reflow Soldering Instructions SMT

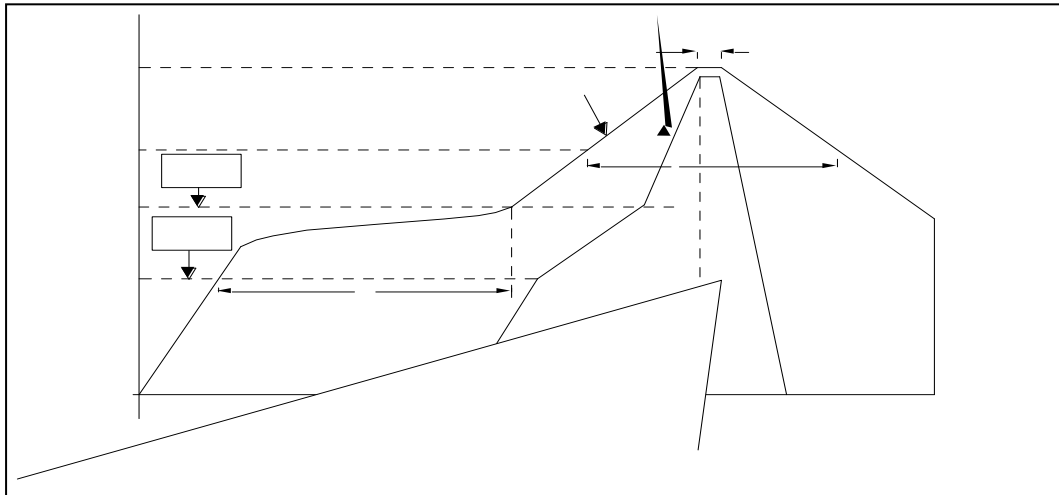

Fig.3-1Title

Table 3-1Title

Average temperature rise speed	T_{smx} T_P	3 °C/ s Max 3 °C/ s
Preheating: minimum temperature	(T_{smin})	150 °C
Preheating: Max temperature	(T_{smx})	200 °C
Preheating: Time	T_{smin} T_{smx}	60 - 120 60s-120s
Time limited to maintain high temperature: the temperature	(T_L)	217 °C
Time limited to maintain high temperature: The Time	(t_L)	60 Max 60s
Peak /Classification of temperature:	/ (T_P)	260 °C
Time limit classification of peak temperature time	t_p	10 Max 10s
Hold time within 5 °C with the actual peak temperature (TP)	(T_P)	30 Max 30s
Cooling speed		6 °C/ s Max 6 °C/ s
Needed time from 25 °C to T_p 25 °C		8 Max 8 minutes

Notes

(1)Reflow soldering should not be done more than two times

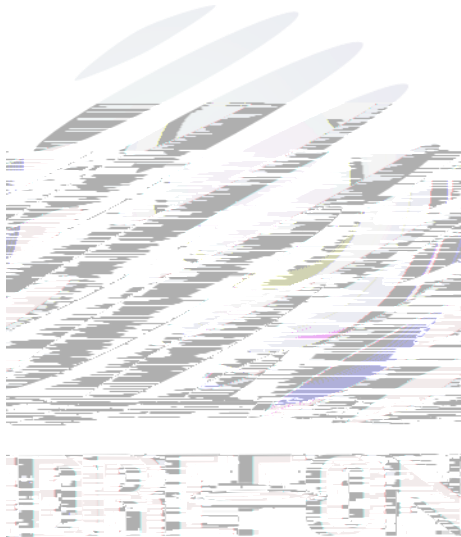

(3) Do not apply mechanical force or excess vibration during the cooling process to normal

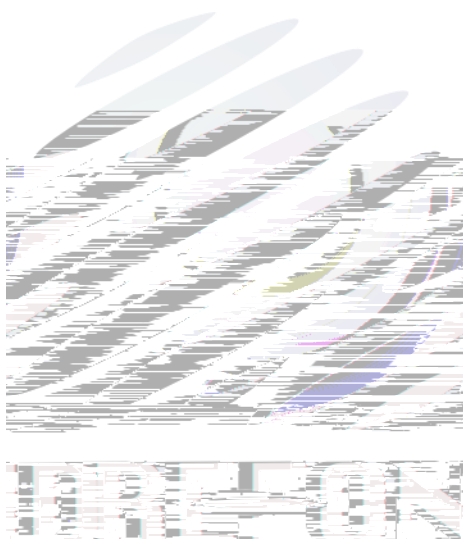

4. Handling Precautions

4.1 Handling Precautions

(1) LED operating environment and sulfur element composition cannot be over 100PPM in the LED mating usage material. This is provided for informational purposes only and is not a warranty or endorsement.LED

(2) In order to prevent external material from getting into the inside of LED, which may cause the malfunction of LED, the single content of Bromine element is required to be less than 900PPM,the single content of Chlorine element is required to be less than 900PPM,the total content of Bromine element and Chlorine element in the external materials of the application products is required to be less than 1500PPM. This is provided for informational purposes only and is not a warranty or endorsement.

(3) VOCs (Volatile organic compounds) emitted from materials used in the construction of fixtures can penetrate silicone encapsulants of LEDs and discolor when exposed to heat and photonic energy. The result can be a significant loss of light output from the fixture. Knowledge of the properties of the materials selected to be used in the construction of fixtures can help prevent these issues. Refond advises against the use of any chemicals or materials that have been found or are suspected to have an adverse affect on device performance or reliability. To verify compatibility, Refond recommends that all chemicals and materials be tested in the specific application and environment for which they are intended to be used. Attaching LEDs, do not use adhesives that outgas organic vapor.

(4) Handle the component along the side surface by using forceps or appropriate tools; do not directly touch or Handle the silicone lens surface, it may damage the internal circuitry.

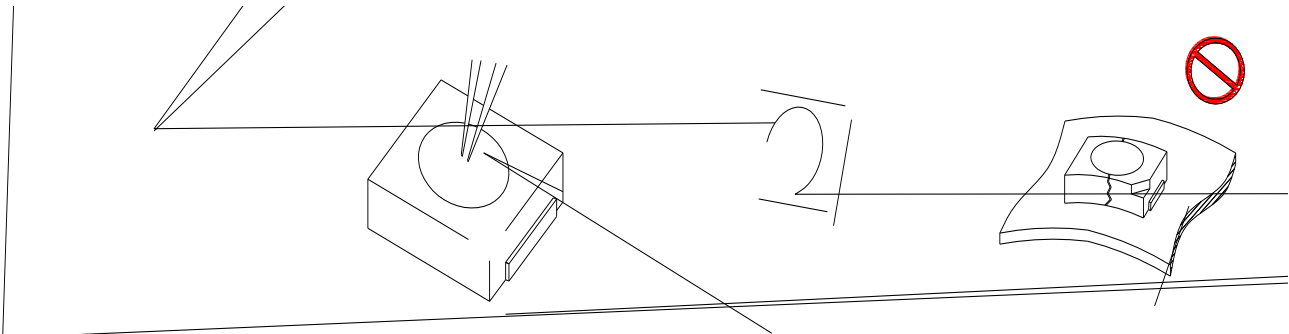
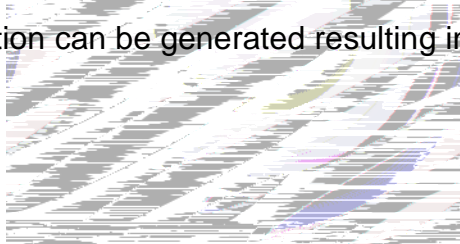

Fig 4-1 Title

(5) In designing a circuit, the current through each LED can not exceed the absolute maximum rating specified for each LED. In the mean while, resistors for protection should be applied, otherwise slight voltage shift will cause big current change, burn out may happen. The driving circuit must be designed to allow forward voltage only when it is ON or OFF. If the reverse voltage is applied to LED, migration can be generated resulting in LED damage.



(6) Thermal Design is paramount importance because heat generation may result in the Characteristics decline, such as brightness decreased, Color change and so on. Please consider the heat generation of the LEDs when making the system design.LED

(7) Compared to standard encapsulants, silicone is generally softer, and the surface is more likely to attract dust , requiring special care during processing. In cases where a minimal level of dirt and dust particles cannot be guaranteed, a suitable cleaning solution must be applied to the surface after the soldering of components. Refond suggests using isopropyl alcohol for cleaning. In case other solvents are used, it must be assured that these solvents do not dissolve the package or resin. Ultrasonic cleaning is not recommended. Ultrasonic cleaning may cause damage to the LED.

Table 4-1 Storage

Conditions		Temperature	Humidity	Time
Storage	Before Opening Aluminum Bag	30	75%	Within 1 Year From Date
	After Opening Aluminum Bag	30	60%	24hours 24
Baking		60±5		24hours 24

(8) If the moisture absorbent material (silica gel) has faded away or the LEDs have exceeded the storage time , baking treatment should be performed after unpacking and based on the following condition (65±5) °C for above 24 hours.

If the package is flatulence or damaged, please notify the sales staff to assist.

(9) Similar to most Solid state devices; LEDs are sensitive to Electro-Static Discharge (ESD) and Electrical Over Stress (EOS).

(10) Other points for attention, please refer to our relevant information.

Version History/

Date	Revisor	Version	Verifier	Remarks
2019-7-26		E2		





www.refond.com

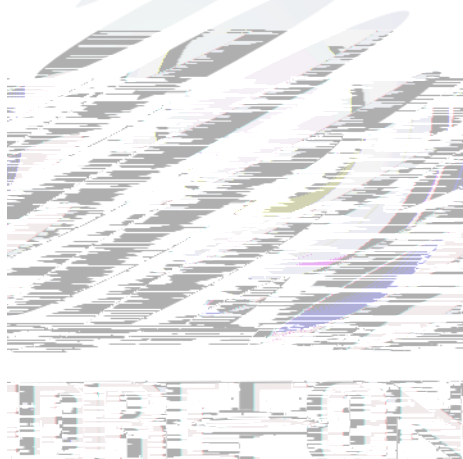

Declare

This specification is written both in English and in Chinese and the latter is formal.