

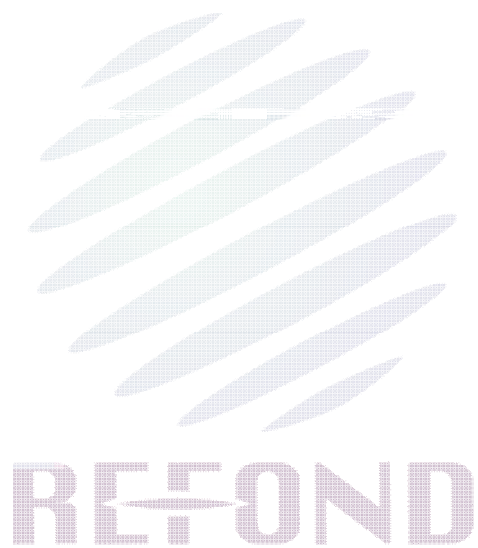

3  
3  
3  
3  
4  
4  
5  
7  
9  
13  
13  
  
14  
14  
15  
16  
17  
17  
19  
19

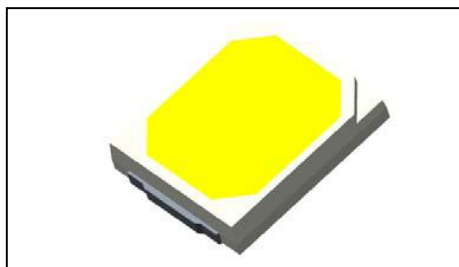



9 ‡ @ 0 ) Å  
.Cñ9N[ .S9N[ Å

5 D Q

Å



9 5 D Q N



U D W L Q J&,pd(^



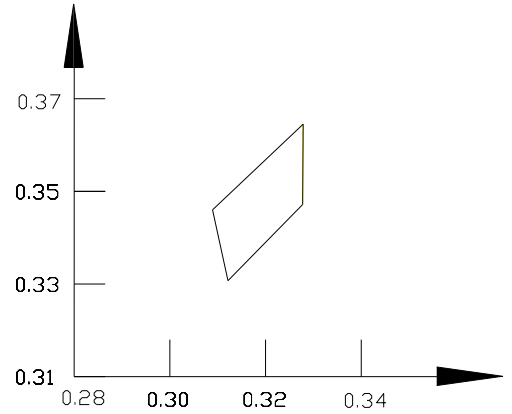
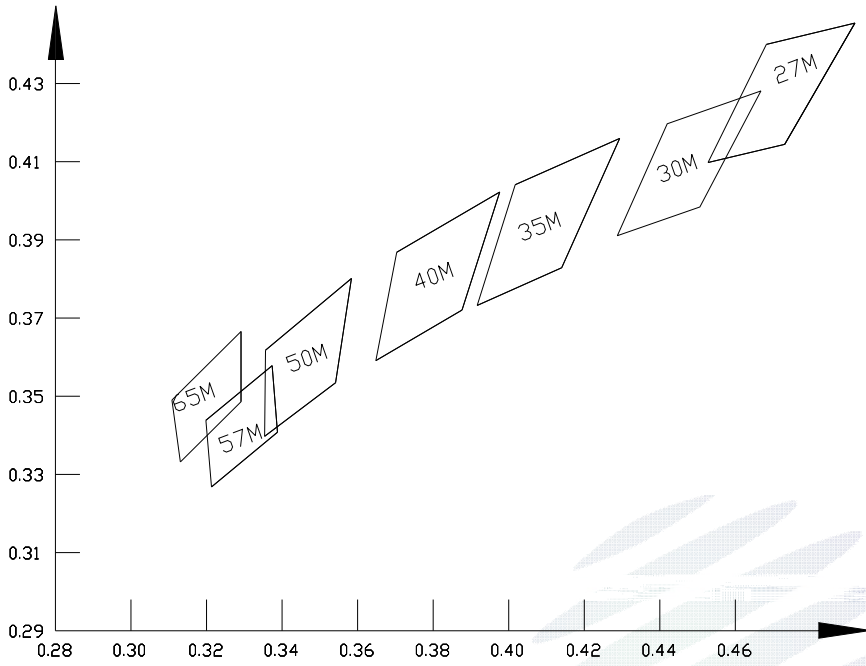

REFOND



REFOND

27M	0.4528	0.4098	0.4731	0.4144	0.4916	0.4455	0.4682	0.4400
30M								
35M	0.4017	0.4041	0.4294	0.4160	0.4140	0.3829	0.3917	0.3732
40M	0.3704	0.3868	0.3976	0.4022	0.3876	0.3721	0.3648	0.3591
50M	0.3356	0.3618	0.3584	0.3801	0.3542	0.3535	0.3354	0.3397
57M	0.3198	0.3438	0.3374	0.3578	0.3388	0.3408	0.3213	0.3268
65N	0.3121	0.3307	0.3277	0.3472	0.3279	0.3645	0.3089	0.3460
65M	0.3131	0.3332	0.3291	0.3486	0.3291	0.3666	0.3108	0.3490

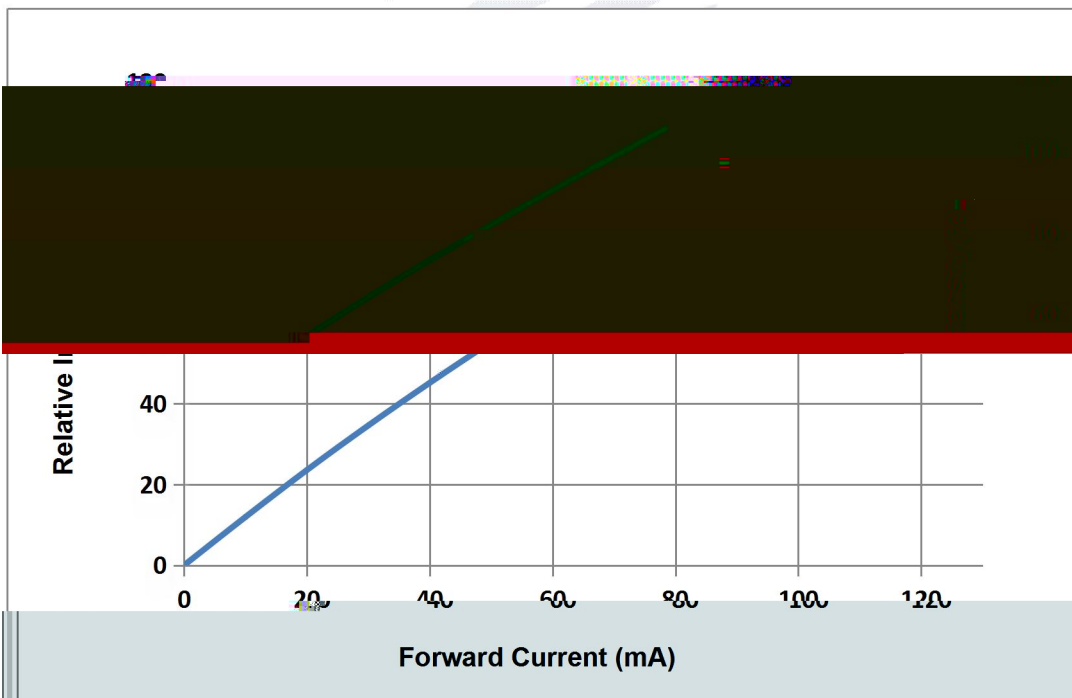
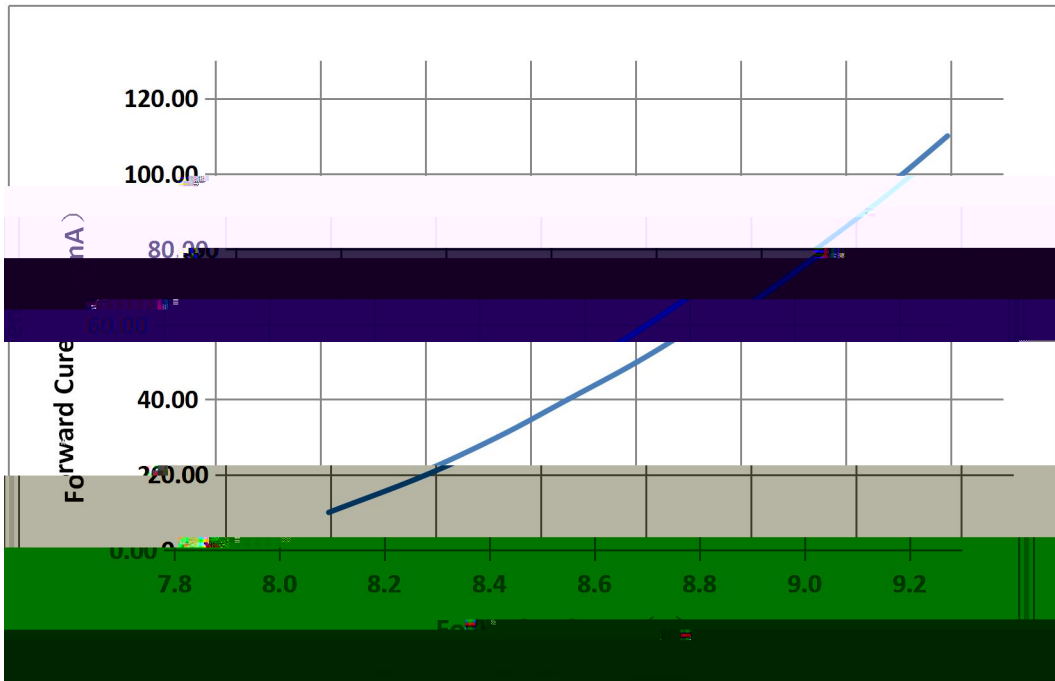



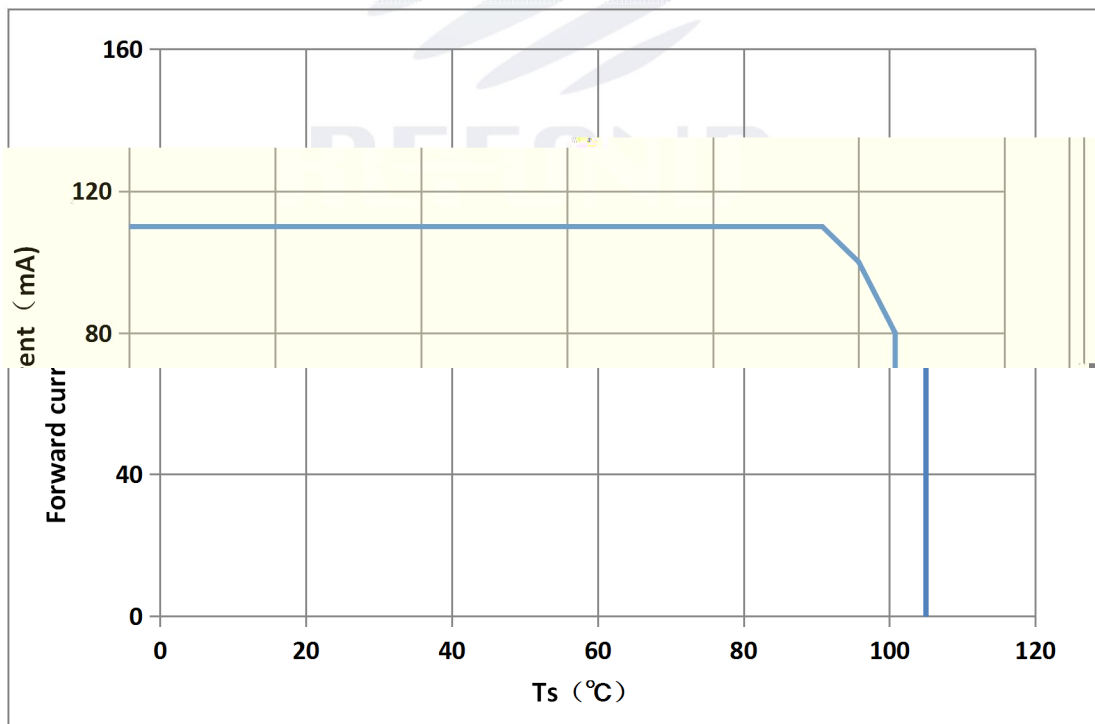
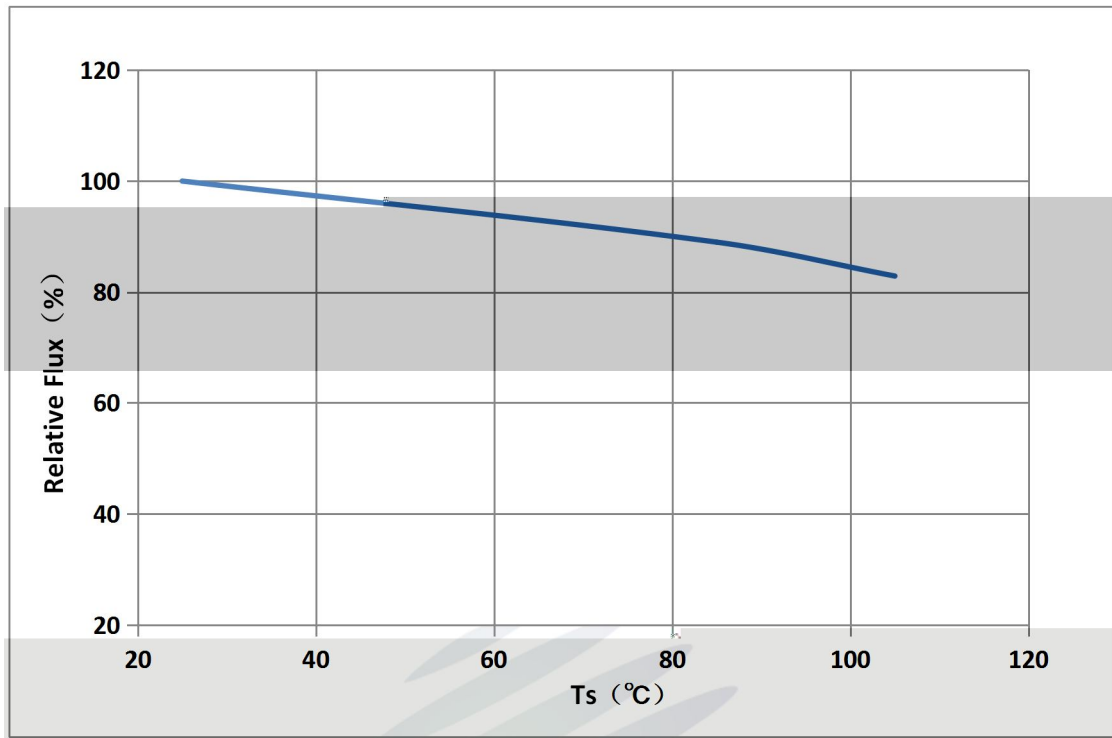

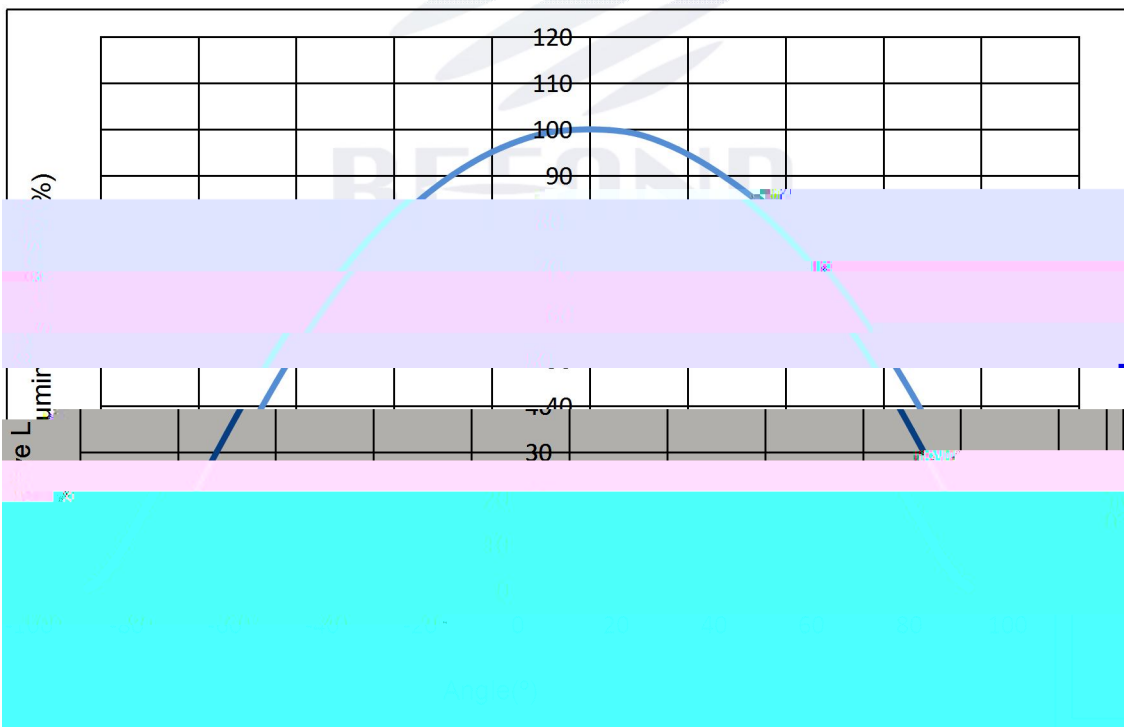
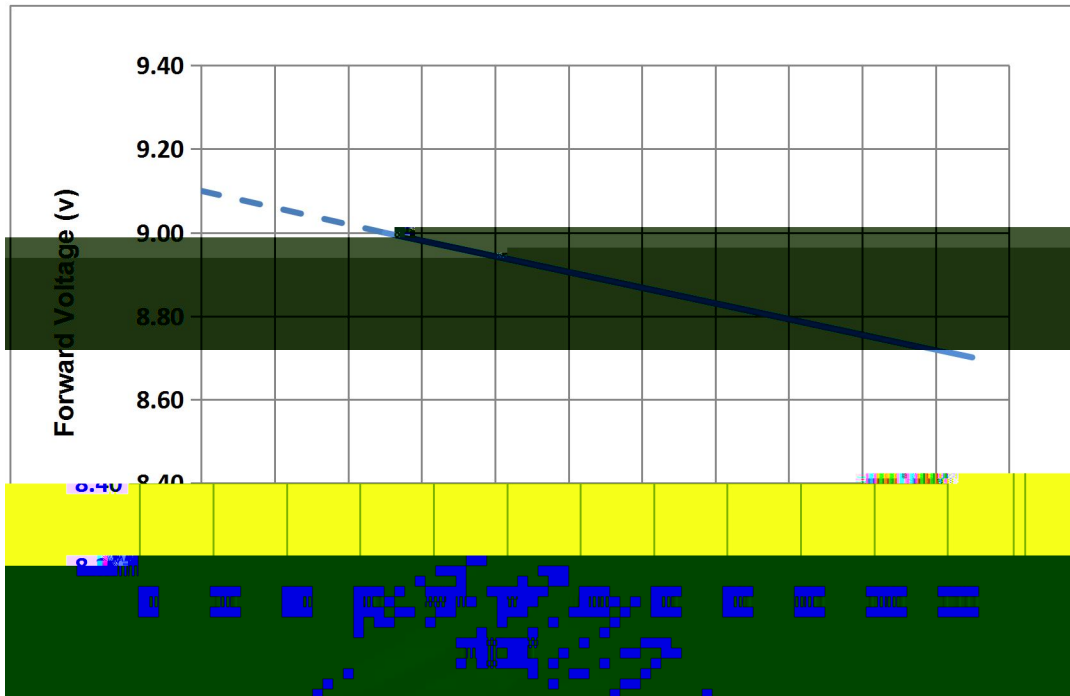

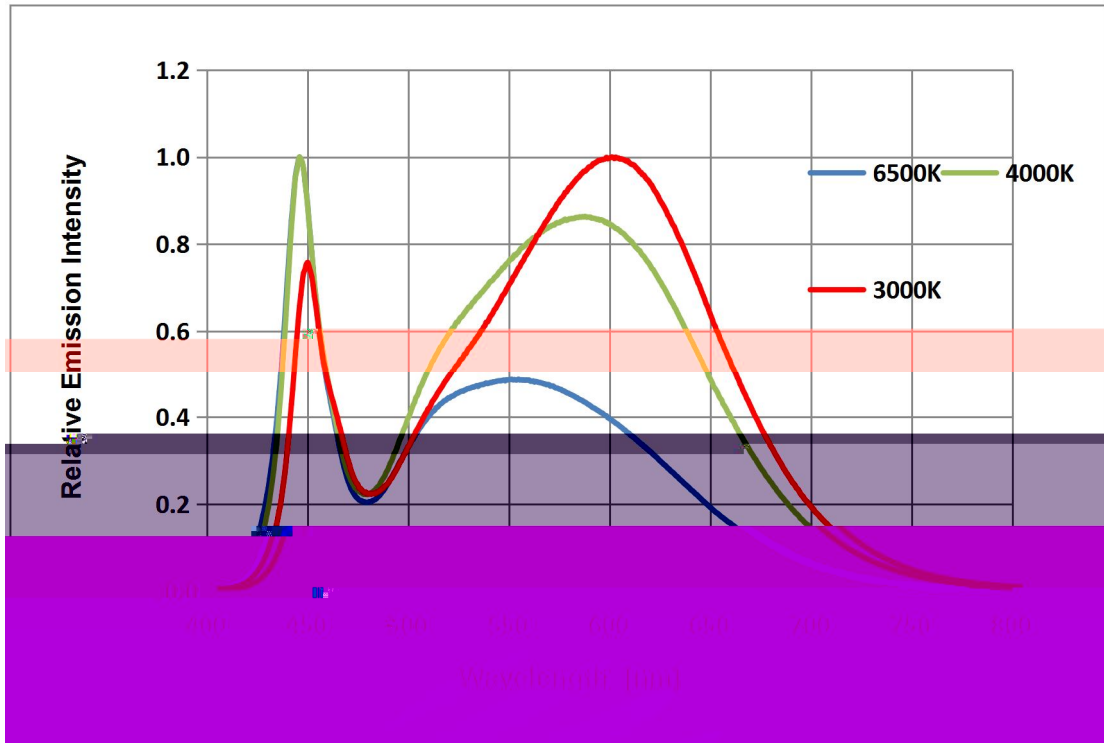



12000pcs

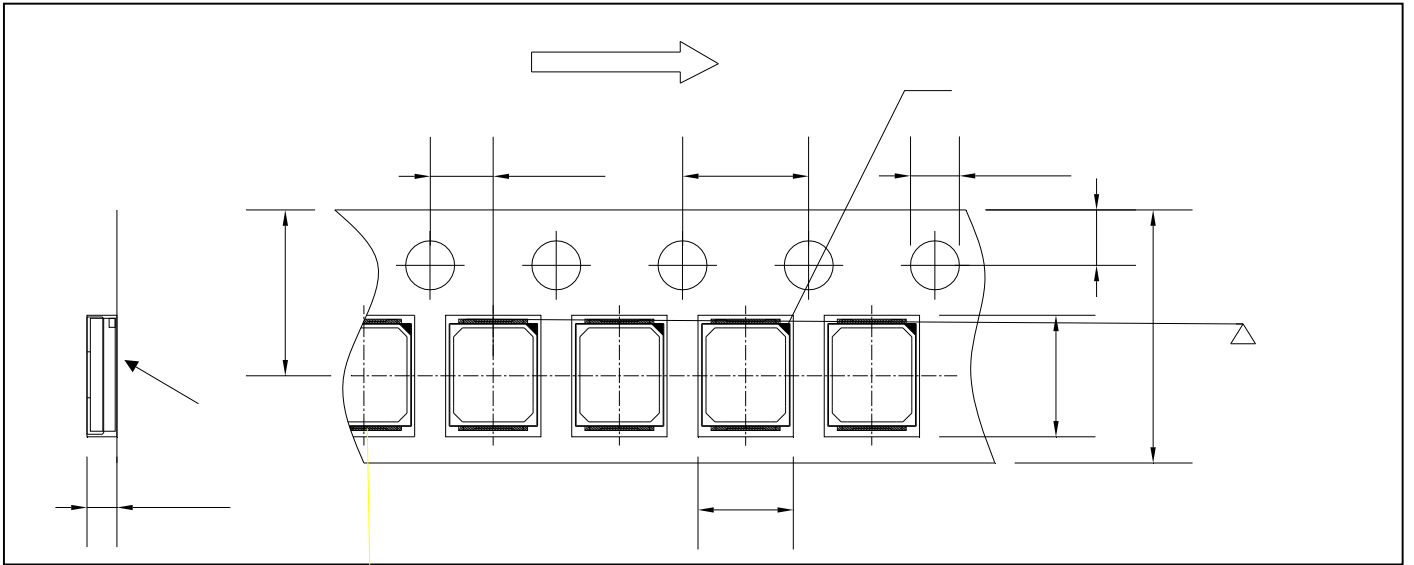

REFOND

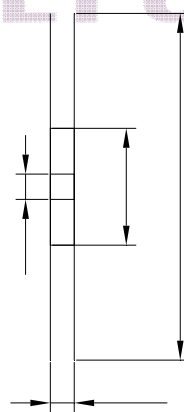
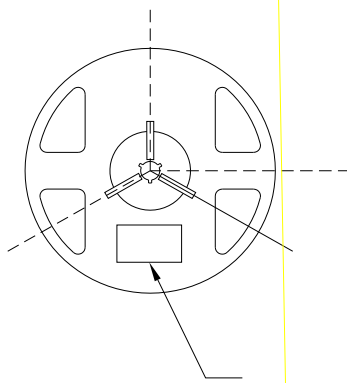



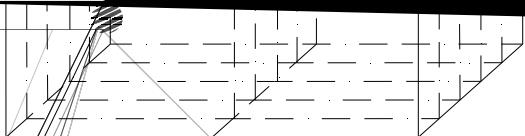
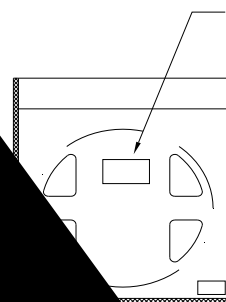

A series of ten horizontal lines, evenly spaced, providing a designated area for handwritten text or notes.

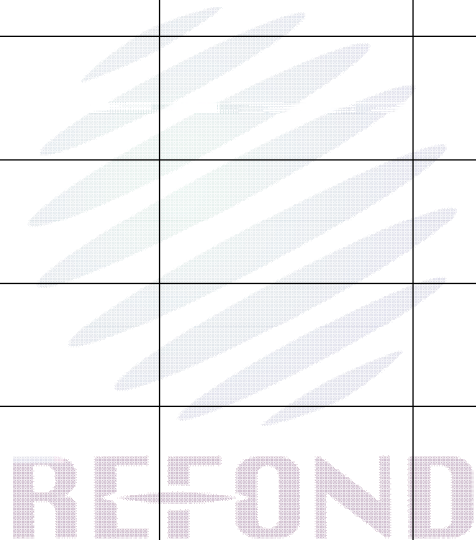

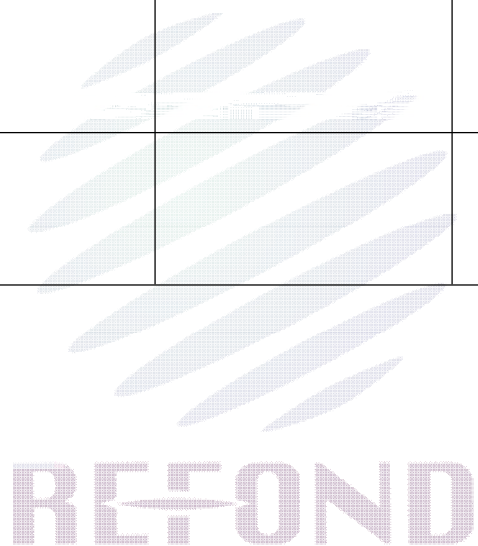









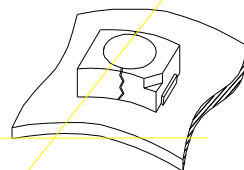
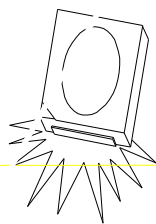



REFOND



瑞豐光電



